STRUCTURAL DESIGN GUIDELINES FOR STEEL MOMENT-RESISTING FRAMES

I. Purpose

This bulletin provides guidelines for application of the design requirements of steel moment-resisting frame structures based on the ASCE 7, AISC 341, AISC 358 and consult with the Structural Engineers Association of Southern California (SEAOSC) Steel Committee according to 2023 LABC. Design criteria included in this bulletin are intended to summarize these standards and recommendations for quick references to steel moment-resisting frame requirements.

II. Codes, Standards, and Specification

- 2023 City of Los Angeles Building Code (LABC).
- AISC 341-16, AISC Seismic Provisions for Structural Steel Buildings, dated July 12, 2016.
- AISC 358-16, AISC358s1-18/s2-20 Pre-qualified Connections for Special and Intermediate Steel Moment Frames for Seismic Applications including Supplemental No.1 and No. 2.
- AISC 360-16, Specification for Structural Steel Buildings.
- ASCE 7-16, Minimum Design Loads for Buildings and Other Structures, including Supplement No. 1 and excluding Chapter 14 and Appendix 11A.
- AWS D1.8/D1.8M-2016, Structural Welding Code-Steel, Seismic Supplement.
- AWS D1.1/D1.1M-2015 Structural Welding Code - Steel.

III. CONNECTION TYPES

A. Prequalified Connection

Currently, AISC 358-16 “Prequalified Connections for Special and Intermediate Steel Moment Frames for Seismic Applications” provides seven prequalified configurations of steel special and intermediate moment-resisting frames, (SMF) and (IMF) respectively, as follows:

- Reduced Beam Section (RBS),
- Bolted Unstiffened Extended End-Plate (BUEEP),
- Bolted Stiffened Extended End-Plate (BSEEP) ,
- Bolted Flange Plate (BFP),
- Welded Unreinforced Flange-Welded Web (WUF-W),
- Kaiser Bolted Bracket (KBB - proprietary product)

- ConXtech ConXL Moment Connection (ConXL - proprietary product)
- SidePlate
- Simpson Strong-Tie Strong Frame
- Double-Tee
- SlottedWeb Moment Connection

The connections illustrated in Figure 1 are considered prequalified connections for SMF and IMF applications, subject to the design and construction limitations as described in AISC 358-16.

Use of any prequalified configuration of steel SMF and IMF in future AISC 358 supplements shall be subject to the review and approval by the Department.

Figure 1 – RBS, BUEEP, BSEEP, BFP, WUF-W, KAISER, ConXL, SidePlate, Simpson Strong-Tie Strong Frame, Double-Tee, and SlottedWeb Connections

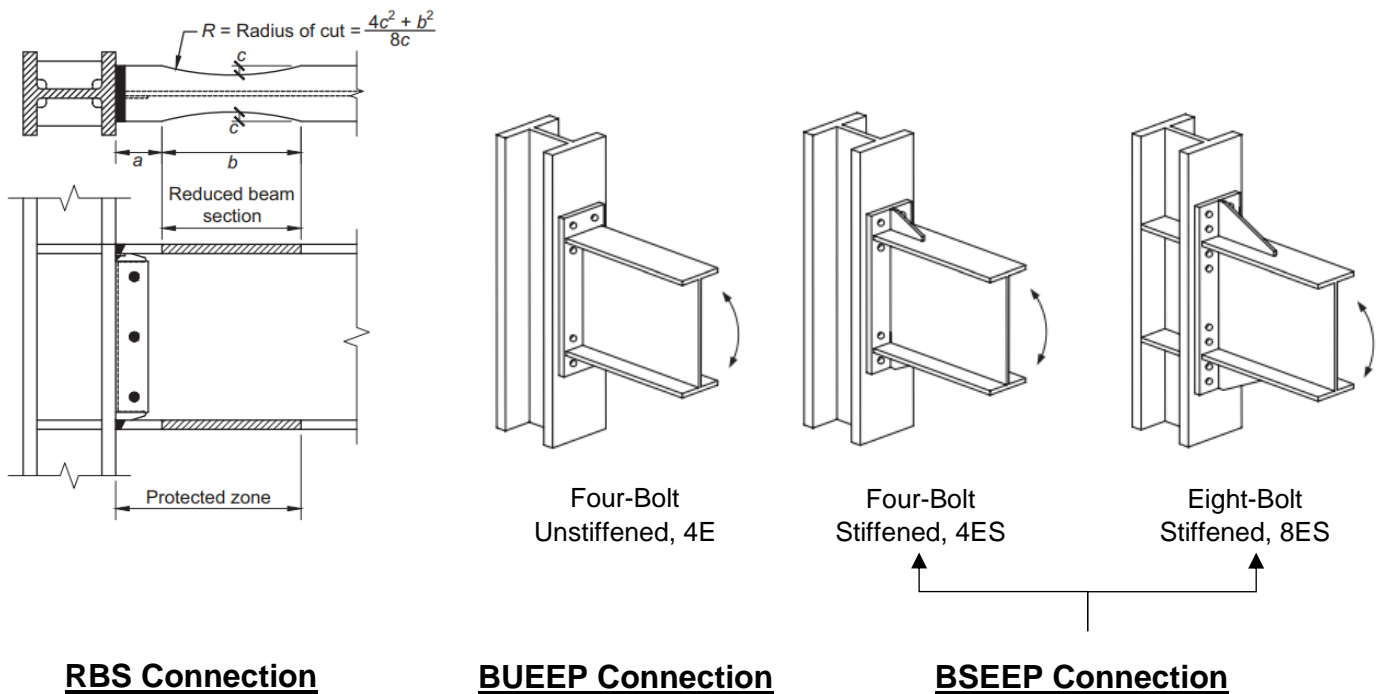

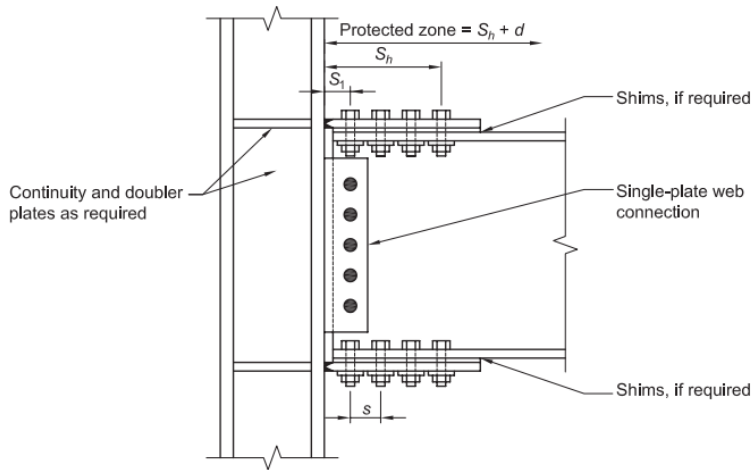

BFP Connection

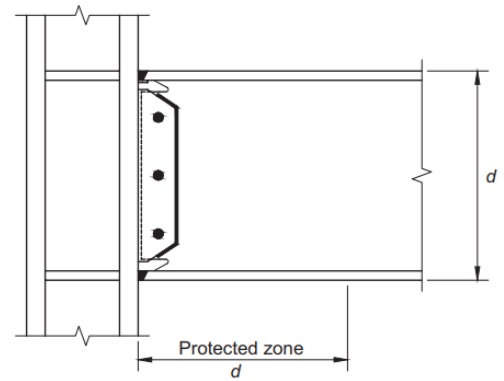

WUF-W Connection

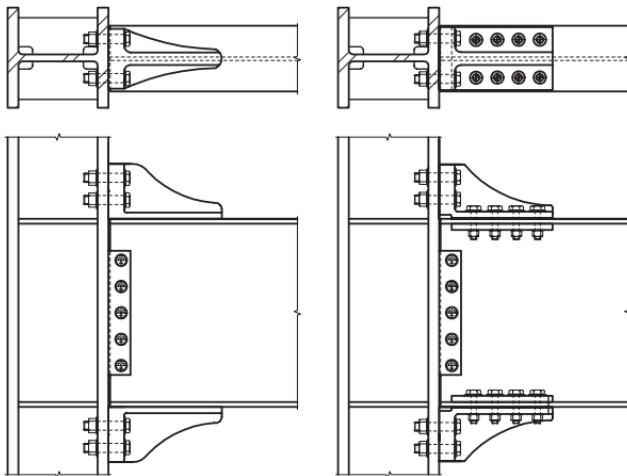

(a) W-Series Connection (b) B-Series Connection

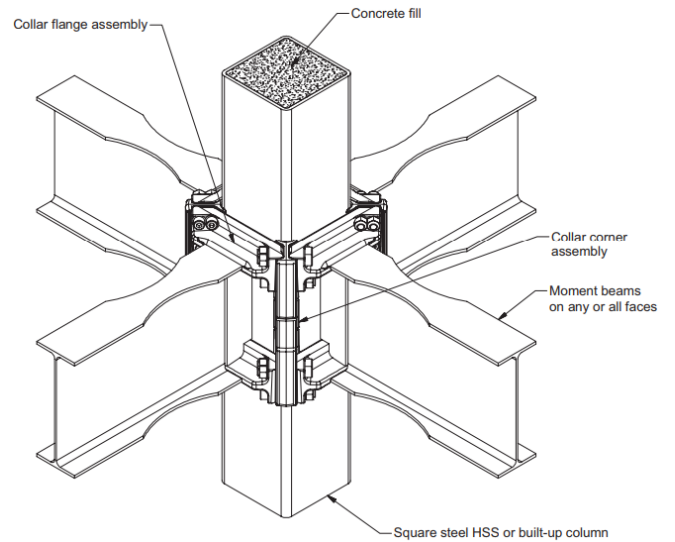

KBB Connection

ConXL Connection

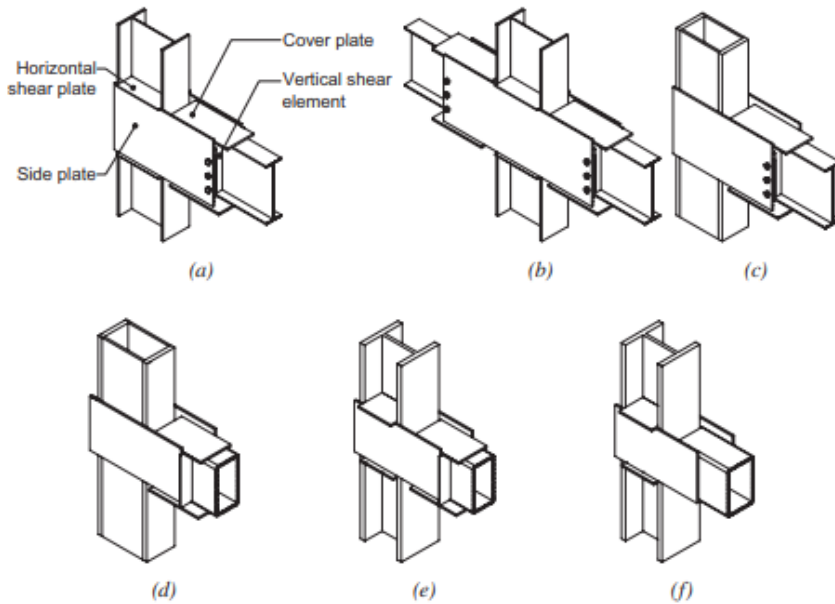

Field-Welded SidePlate
Connection

Assembled SidePlate uniaxial configurations: (a) one-sided wide flange beam and column construction; (b) two-sided wide-flange beam and column construction; (c) wide-flange beam to built-up box column; (d) HSS beam without cover plates to wide-flange column; (e) HSS beam with cover plates to wide-flange column; and (f) HSS beam with cover plates to built-up box column.

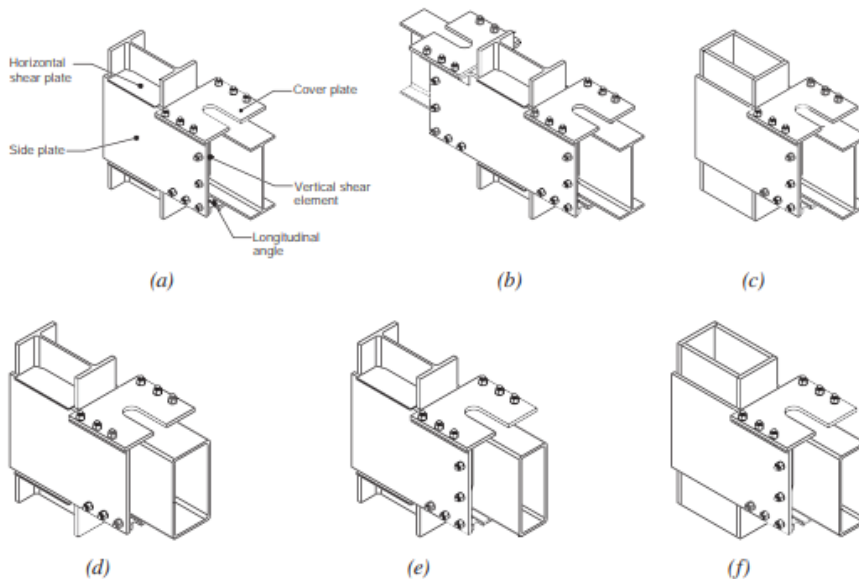

Field-Bolted SidePlate
Connection

Assembled SidePlate uniaxial field-bolted standard configurations (configuration A): (a) one-sided wide-flange beam and column construction; (b) two-sided wide-flange beam and column construction; (c) wide-flange beam to either HSS or built-up box column; (d) HSS beam to wide-flange column; (e) HSS beam with cover plate to wide-flange column; and (f) HSS beam with cover plates to either HSS or built-up box column.

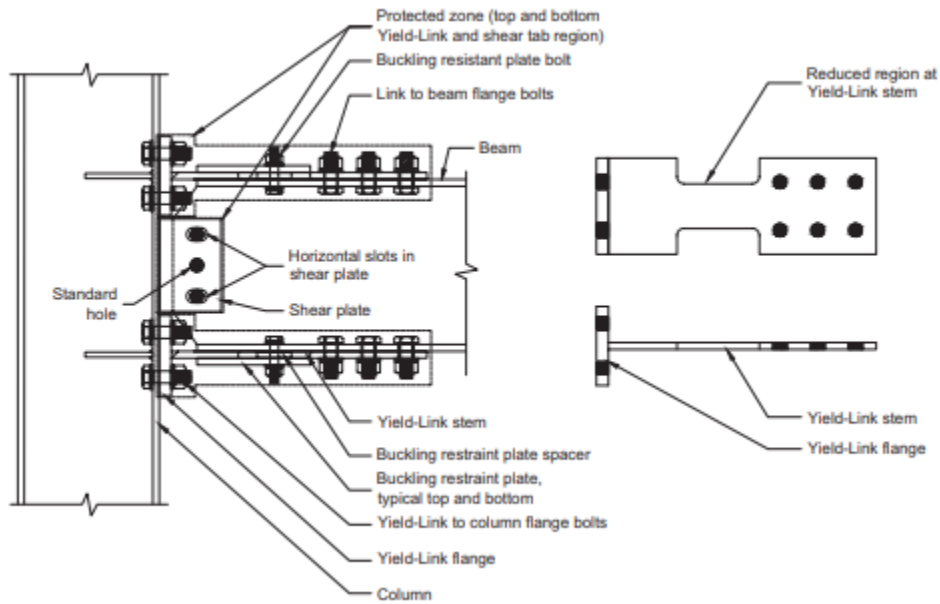

Simpson Strong-Tie Strong Frame Connection

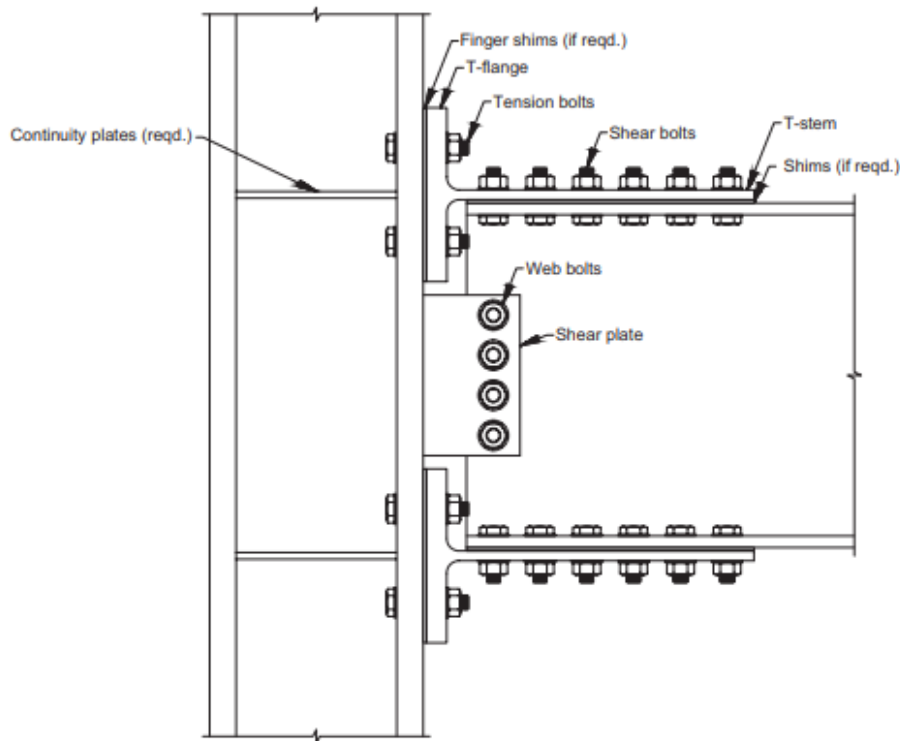

Double-Tee Connection

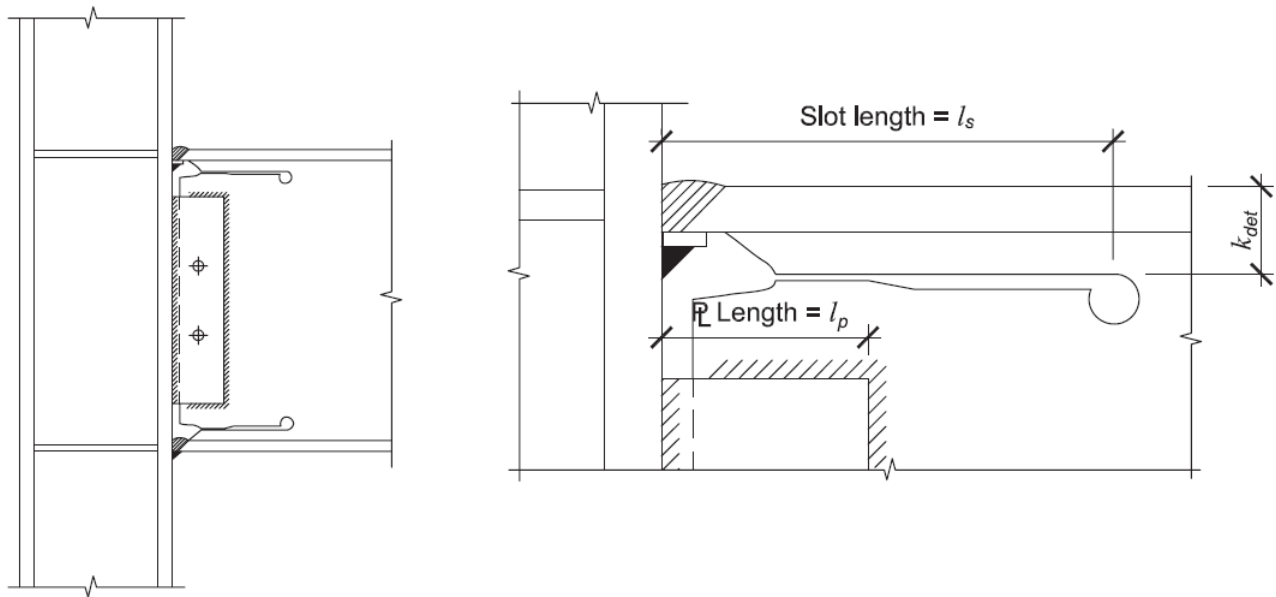

SlottedWeb (SW) Connection

B. Non-Prequalified Connection

Connections that are not described in Section-A above are considered as non-prequalified connections. The non-qualified connections must be tested in accordance with Chapter K of AISC 341-16. Such testing shall be approved by LADBS or by a national recognized model code agency per P/BC 2023-119. Where connection configurations are based on previously tested SMFs or IMFs, the extrapolation of tests to only those connections shall be limited to those that are within the size and weight variation for beams and columns as specified in Chapter K of AISC 341-16.

When variations of any connection systems are proposed, project specific tests complying with Chapter K of AISC 341-16 are required for the following:

- Skewed or dual axis moment connections,
- Moment connections in the weak axis direction of the column (e.g., moment connections to the column web),
- Variations from the allowed configuration of the weld access hole at moment connections,
- Addition of haunches or cover plates,
- Additional welding and other connections not prequalified.

IV. STRUCTURAL DESIGN CRITERIA

The following design criteria shall be used for SMF and IMF designed and prequalified with-AISC 358-16 and AISC 341-16 Seismic Provisions for rolled or built-up I-shaped sections (i.e., wide flange shapes):

1. The appropriate response modification coefficient, R , system overstrength factor, Ω_o , and the deflection amplification factor, C_d , indicated in Table 12.2-1 of ASCE 7-16 shall be used to determine the base shear, element design forces, and design story drift.
2. The structural system used shall be in accordance with the seismic design category and height limitations indicated in Table 12.2-1 and Section 12.2.5.5 of ASCE 7-16 (for SMF) or Sections 12.2.5.6 thru 12.2.5.7 of ASCE 7-16 (for OMF and IMF)

Exception:

A greater allowable story drift may be permitted if it can be demonstrated from tests, conforming to Chapter K of AISC 341-16, that the connection provides a drift capacity of 1.6 times the proposed allowable story drift. The allowable story drift determined by this process shall not exceed that permitted by Table 12.2-1 of ASCE 7-16 for any story.

V. OTHER DESIGN CONSIDERATIONS

A. Overstrength Factor at Column Base Connection

Column base connection elements, including but not limited to, anchor bolts, base plate welds and any elements transferring shear, moment and tension mechanism shall be designed using the overstrength factor, Ω_o , in accordance with Section 12.4.3 of ASCE 7-16. Load combinations with overstrength factor should apply to elevated structural slabs or beams supporting moment-resisting frame systems. The overstrength factor, Ω_o , need not be applied to the foundation or grade beam supporting columns; provided however that the grade beams are designed and detailed to develop ductility in accordance with the provisions of Chapter 21 of ACI-318-19.

B. Protected Zones for SMF and IFM Connections

The region at each end of the beam subject to inelastic straining shall be designated as a protected zone and shall meet the requirements of Section D1.3 of AISC 341-16. Unless a prequalified connection is used in accordance with Section K1 of AISC 341-16, cyclic testing is required for the qualification of the connection in accordance with Section K2 of AISC 341-16.

Unless otherwise permitted per Section D1.3 of AISC 341-16, discontinuities created by fabrication or erection operations and attachments or penetrations within the protected zones are prohibited. This requirement shall be clearly identified on the structural drawings. Figure 2 below shows recommended details to prohibit attachments or penetrations in the protected zones. Furthermore, it is recommended this detail be shown on other appropriate construction documents, including the architectural, mechanical, electrical or plumbing drawings. The importance of avoiding attachments or penetrations within the protected zones should be discussed during the preconstruction meeting with the various contractors and subcontractors prior to commencement of construction work.

Note: While the AISC 341-16 does not require protected zones for OMF connections, it is good practice to minimize or limit, whenever possible, attachments within this defined area.

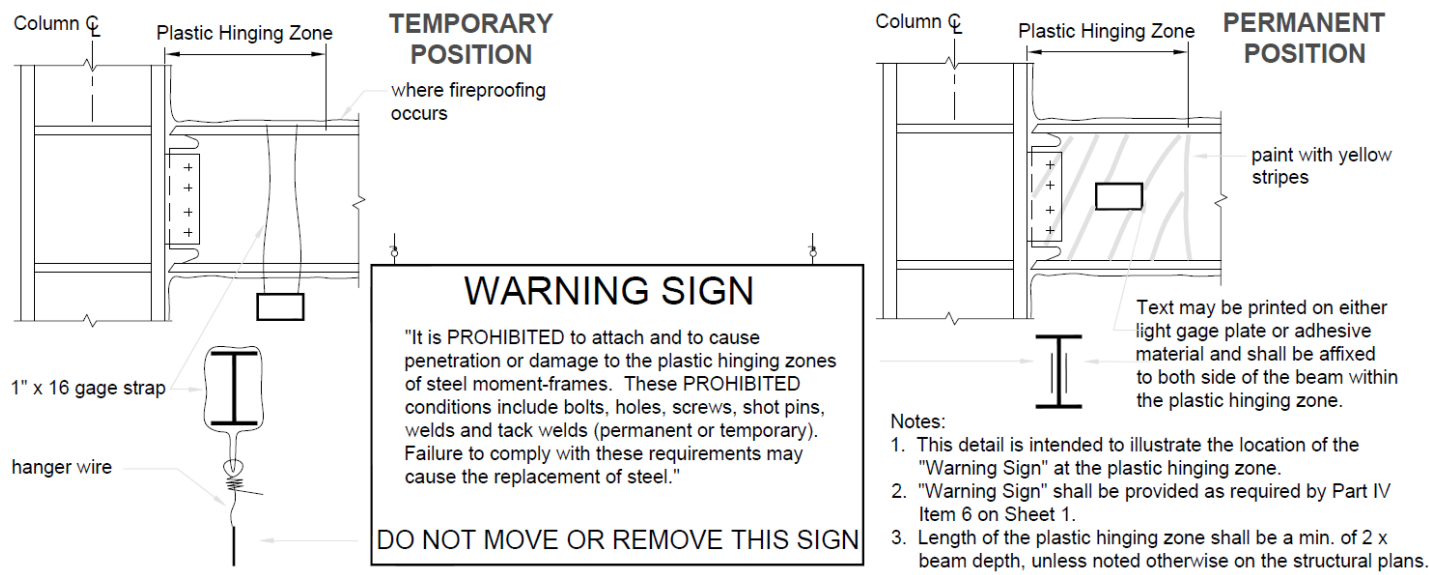

Figure 2 – Protected Zone

VI. QUALITY CONTROL AND QUALITY ASSURANCE

Quality control and quality assurance shall be in accordance with Chapter J of AISC 341-16. Details regarding welding and welding inspection shall be in accordance with AWS D1.1-15 Steel Structural Welding Code, D1.8-16 Steel Structural Welding Code - Seismic Supplement, Chapter I of AISC 341-16 and Chapter 3 of AISC 358-16.

A quality assurance plan is required to be provided with every structural plan for steel moment frames. Quality Assurance (QA) Standard Plans shall be attached to and made part of the approved structural plans, per Chapter J of AISC 341-16. The Engineer of Record shall submit a separate quality assurance plan complies with all the minimum requirements.

As an option, the Engineer of Record can amend and use LADBS's Quality Assurance Standard Plans as a template to satisfy the current AISC 341-16, Chapter J requirements. Providing that if any modification or mixing and matching from the standard plans, the amended plans shall be no less meeting Chapter J requirement as LADBS intended. The QA Standard Plan template can be obtained at www.ladbs.org.

**TABLE 1
SUMMARY OF DESIGN COEFFICIENTS, FACTORS AND DEFORMATION FOR
STEEL MOMENT-RESISTING FRAMES SYSTEMS IN SEISMIC DESIGN CATEGORY D**

LFRS	CONNECTION TYPE	STANDARD	SECTION	BUILDING AND STRUCTURE TYPES	DESIGN COEFFICIENTS AND FACTORS			SEISMIC DESIGN CATEGORY Structural System Limitations and Building Height Limit ^c				OCCUPANCY CATEGORY Allowable Story Drift Limit ^{e, f}					
					R ^a	Q _s ^d	C _s ^b	D				≤ 4 Stories			> 4 Stories		
								HT	DL	WDL	Story	I or II	III	IV	I or II	III	IV
SMF ^g	AISC 358 Prequalified Connections	AISC-358	Table 2.1.	Any Building Types	8	3	5.5	NL	NL	NL	NL	0.025h _{xx}	0.020h _{xx}	0.015h _{xx}	0.020h _{xx}	0.015h _{xx}	0.010h _{xx}
	Connection Qualified by Cyclic Test	AISC-341	Chapter K	Any Building Types	8	3	5.5	NL	NL	NL	NL	0.025h _{xx}	0.020h _{xx}	0.015h _{xx}	0.020h _{xx}	0.015h _{xx}	0.010h _{xx}
IMF	AISC 358 Prequalified Connections	AISC-358	Table 2.1.	Any Building Types	4.5	3	4	35	NL	NL	NL	0.020h _{xx}	0.020h _{xx}	0.015h _{xx}	0.020h _{xx}	0.015h _{xx}	0.010h _{xx}
	Connection Qualified by Cyclic Test	AISC-341	Chapter K	Any Building Types	4.5	3	4	35	NL	NL	NL	0.020h _{xx}	0.020h _{xx}	0.015h _{xx}	0.020h _{xx}	0.015h _{xx}	0.010h _{xx}
	Moment Joint Field Connection Constructed of Bolted End Plates ^{h, k}	AISC-341	Section E2	Metal Buildings	4.5	3	4	65	20	20	1	0.020h _{xx}	0.020h _{xx}	0.015h _{xx}	NP	NP	NP
OMF	AISC 358 Prequalified Connections, But not meeting all requirements	AISC-358	Table 2.1.	Light-Frame Construction	3.5	3	3	35	35	20	NL	0.015h _{xx}	0.015h _{xx}	0.015h _{xx}	0.015h _{xx}	0.015h _{xx}	0.010h _{xx}
	Beam to Column Connection of Rolled or Built-Up I-Shape Sections Wide Flange Shapes ^l	AISC-341	Section E1	Light-Frame Construction	3.5	3	3	35	35	20	NL	0.015h _{xx}	0.015h _{xx}	0.015h _{xx}	0.015h _{xx}	0.015h _{xx}	0.010h _{xx}
	Moment Joint Field Connection Constructed of Bolted End Plates ^{h, k}	AISC-341	Section E1	Metal Buildings	3.5	3	3	65	20	20	1	0.020h _{xx}	0.020h _{xx}	0.015h _{xx}	NP	NP	NP
	Beam to Column Connection with Other Symmetrical Shapes ^l	AISC-341	Section E1	Light-Frame Construction or Miscellaneous Structures ^m	1.5	1.5	1.5	35	NL	NL	NL	0.015h _{xx}	NP	NP	0.015h _{xx}	NP	NP

FOOTNOTE:

- Response modification coefficient R, for use throughout the standard. Note R reduces forces to a strength level, not an allowable stress level.
- Reflection amplification factor, C_d, for use in ASCE 7-16 Sections 12.8.6, 12.8.7, and 12.9.2
- NL = Not Limited, NP = Not Permitted, DL = roof or floor tributary dead load in accordance with ASCE 7-16 Section 12.2.5.6, 12.2.5.7, 12.2.5.8, WDL = exterior wall tributary dead load in accordance with ASCE 7-16 Section 12.2.5.6, 12.2.5.7, 12.2.5.8, HT = Heights are measured from the base of the structure as defined in ASCE 7-16 Section 11.2, For metric units use 30.5m for 100ft and use 48.8m for 160 ft, Story as defined in ASCE 7-16 section 11.2.
- The tabulated value of the overstrength factor, Q_s, is permitted to be reduced by subtracting one-half for structures with flexible diaphragms, but shall not be taken as less than 2.0 for any structure except cantilever column system.
- See ASCE 7-16 Section 12.2.5.5 for limitations for steel SMFs in structures assigned to Seismic Design Category D through F.
- See ASCE 7-16 Section 12.2.5.6 and 12.2.5.7 for limitations for single-story steel OMFs and IMFs in structures assigned to Seismic Design Category D through F.
- See ASCE 7-16 Section 12.2.5.6 and 12.2.5.7 for limitations for steel OMFs and IMFs in structures assigned to Seismic Design Category D through E.
- See ASCE 7-16 Section 12.2.5.7 for limitations for steel IMFs in structure assigned to Seismic Design Category F.
- See ASCE 7-16 Section 12.12.1.1 for the allowable story drift for seismic force-resisting systems comprised solely of moment frames in Seismic Design Category D through F.
- See AISC 358-16 Table 2.1 for connections and limitations for prequalified steel SMFs with concrete structural slabs in direct contact with the steel.
- The connections in this table are intended for rolled or built-up I-shaped sections (i.e., wide flange shapes).
- Other double symmetrical (symmetrical to both bending axes) shapes may include, but not limited to, channels, built-up sections (non I-shaped), and hollow structural sections (HSS).
- Miscellaneous structures may include, but not limited to, walkways, canopies, penthouse, stairs towers, and other non-building structures not part of the lateral resisting system of a building.

As a covered entity under Title II of the Americans with Disabilities Act, the City of Los Angeles does not discriminate on the basis of disability and, upon request, will provide reasonable accommodation to ensure equal access to its programs, services and activities. For efficient handling of information internally and in the internet, conversion to this new format of code related and administrative information bulletins including MGD and RGA that were previously issued will allow flexibility and timely distribution of information to the public

**TABLE 2
SUMMARY OF DESIGN COEFFICIENTS, FACTORS AND DEFORMATION FOR
STEEL MOMENT-RESISTING FRAMES SYSTEMS IN SEISMIC DESIGN CATEGORY E**

LFRS	CONNECTION TYPE	STANDARD	SECTION	BUILDING AND STRUCTURE TYPES	DESIGN COEFFICIENTS AND FACTORS			SEISMIC DESIGN CATEGORY Structural System Limitations and Building Height Limit ^c				OCCUPANCY CATEGORY Allowable Story Drift Limit ^{e, f}					
					R ^a	Ω_c ^d	C _e ^b	E				≤ 4 Stories			> 4 Stories		
								HT	DL	WDL	Story	I or II	III	IV	I or II	III	IV
SMF	AISC 358 Prequalified Connections	AISC-358	Table 2.1,	Any Building Types	8	3	5.5	NL	NL	NL	NL	0.025h _{xx}	0.020h _{xx}	0.015h _{xx}	0.020h _{xx}	0.015h _{xx}	0.010h _{xx}
	Connection Qualified by Cyclic Test	AISC-341	Chapter K	Any Building Types	8	3	5.5	NL	NL	NL	NL	0.025h _{xx}	0.020h _{xx}	0.015h _{xx}	0.020h _{xx}	0.015h _{xx}	0.010h _{xx}
MF	AISC 358 Prequalified Connections	AISC-358	Table 2.1,	Any Building Types	4.5	3	4	35	35	20	NL	0.020h _{xx}	0.020h _{xx}	0.015h _{xx}	0.020h _{xx}	0.015h _{xx}	0.010h _{xx}
	Connection Qualified by Cyclic Test	AISC-341	Chapter K	Any Building Types	4.5	3	4	35	35	20	NL	0.020h _{xx}	0.020h _{xx}	0.015h _{xx}	0.020h _{xx}	0.015h _{xx}	0.010h _{xx}
	Moment Joint Field Connection Constructed of Bolted End Plates ^{g,h,i}	AISC-341	Section E2	Metal Buildings	4.5	3	4	65	20	20	1	0.020h _{xx}	0.020h _{xx}	0.015h _{xx}	NP	NP	NP
OMF	AISC 358 Prequalified Connections, But not meeting all requirements	AISC-358	Table 2.1,	Light-Frame Construction	3.5	3	3	35	35	20	NL	0.015h _{xx}	0.015h _{xx}	0.015h _{xx}	0.015h _{xx}	0.015h _{xx}	0.010h _{xx}
	Beam to Column Connection of Rolled or Built-Up I- Shaped Sections Wide Flange Shapes ^k	AISC-341	Section E1	Light-Frame Construction	3.5	3	3	35	35	20	NL	0.015h _{xx}	0.015h _{xx}	0.015h _{xx}	0.015h _{xx}	0.015h _{xx}	0.010h _{xx}
	Moment Joint Field Connection Constructed of Bolted End Plates ^g	AISC-341	Section E1	Metal Buildings	3.5	3	3	65	20	20	1	0.020h _{xx}	0.020h _{xx}	0.015h _{xx}	NP	NP	NP
	Beam to Column Connection with Other Symmetrical Shapes ^l	AISC-341	Section E1	Light-Frame Construction or Miscellaneous Structures ^m	1.5	1.5	1.5	35	NL	NL	NL	0.015h _{xx}	NP	NP	0.015h _{xx}	NP	NP

FOOTNOTE:

- Response modification coefficient R, for use throughout the standard. Note R reduces forces to a strength level, not an allowable stress level.
- Reflection amplification factor, C_d, for use in ASCE 7-16 Sections 12.8.6, 12.8.7, and 12.9.2
- NL = Not Limited, NP = Not Permitted., DL = roof or floor tributary dead load in accordance with ASCE 7-16 Section 12.2.5.6, 12.2.5.7, 12.2.5.8, HT = exterior wall tributary dead load in accordance with ASCE 7-16 Section 12.2.5.6, 12.2.5.7, 12.2.5.8, WDL = exterior wall tributary dead load in accordance with ASCE 7-16 Section 12.2.5.6, 12.2.5.7, 12.2.5.8, HT = Heights are measured from the base of the structure as defined in ASCE 7-16 Section 11.2, For metric units use 30.5m for 100ft and use 48.8m for 160 ft, Story as defined in ASCE 7-16 section 11.2.
- The tabulated value of the overstrength factor, Ω_c , is permitted to be reduced by subtracting one-half for structures with flexible diaphragms, but shall not be taken as less than 2.0 for any structure except cantilever column system.
- See ASCE 7-16 Section 12.2.5.5 for limitations for steel SMFs in structures assigned to Seismic Design Category D through F.
- See ASCE 7-16 Section 12.2.5.6 and 12.2.5.7 for limitations for single-story steel OMFs and IMFs in structures assigned to Seismic Design Category D through F.
- See ASCE 7-16 Section 12.2.5.6 and 12.2.5.7 for limitations for steel OMFs and IMFs in structures assigned to Seismic Design Category D through E.
- See ASCE 7-16 Section 12.2.5.7 for limitations for steel IMFs in structure assigned to Seismic Design Category F.
- See ASCE 7-16 Section 12.12.1.1 for the allowable story drift for seismic force-resisting systems comprised solely of moment frames in Seismic Design Category D through F.
- See AISC 358-16 Table 2.1 for connections and limitations for prequalified steel SMFs with concrete structural slabs in direct contact with the steel.
- The connections in this table are intended for rolled or built-up I-shaped sections (i.e., wide flange shapes).
- Other double symmetrical (symmetrical to both bending axes) shapes may include, but not limited to, channels, built-up sections (non I-shaped), and hollow structural sections (HSS).
- Miscellaneous structures may include, but not limited to, walkways, canopies, penthouse, stairs towers, and other non-building structures not part of the lateral resisting system of a building.

As a covered entity under Title II of the Americans with Disabilities Act, the City of Los Angeles does not discriminate on the basis of disability and, upon request, will provide reasonable accommodation to ensure equal access to its programs, services and activities. For efficient handling of information internally and in the internet, conversion to this new format of code related and administrative information bulletins including MGD and RGA that were previously issued will allow flexibility and timely distribution of information to the public

**TABLE 3
SUMMARY OF DESIGN COEFFICIENTS, FACTORS AND DEFORMATION FOR
STEEL MOMENT-RESISTING FRAMES SYSTEMS IN SEISMIC DESIGN CATEGORY F**

LFRS	CONNECTION TYPE	STANDARD	SECTION	BUILDING AND STRUCTURE TYPES	DESIGN COEFFICIENTS AND FACTORS			SEISMIC DESIGN CATEGORY Structural System Limitations and Building Height Limit ^c				OCCUPANCY CATEGORY Allowable Story Drift Limit ^{e, f}					
					R ^a	Ω_p ^d	C _e ^b	F				≤ 4 Stories			> 4 Stories		
								HT	DL	WDL	Story	I or II	III	IV	I or II	III	IV
SMF ^g	AISC 358 Prequalified Connections	AISC-358	Table 2.1.	Any Building Types	8	3	5.5	NL	NL	NL	NL	0.025h _{xx}	0.020h _{xx}	0.015h _{xx}	0.020h _{xx}	0.015h _{xx}	0.010h _{xx}
	Connection Qualified by Cyclic Test	AISC-341	Chapter K	Any Building Types	8	3	5.5	NL	NL	NL	NL	0.025h _{xx}	0.020h _{xx}	0.015h _{xx}	0.020h _{xx}	0.015h _{xx}	0.010h _{xx}
IMF ^h	AISC 358 Prequalified Connections	AISC-358	Table 2.1.	Light-Frame Construction	4.5	3	4	35	35	20	NL	0.020h _{xx}	0.020h _{xx}	0.015h _{xx}	0.020h _{xx}	0.015h _{xx}	0.010h _{xx}
	Connection Qualified by Cyclic Test	AISC-341	Chapter K	Light-Frame Construction	4.5	3	4	35	35	20	NL	0.020h _{xx}	0.020h _{xx}	0.015h _{xx}	0.020h _{xx}	0.015h _{xx}	0.010h _{xx}
	Moment Joint Field Connection Constructed of Bolted End Plates ^{i,k,m}	AISC-341	Section E2	Metal Buildings	4.5	3	4	65	20	20	1	0.020h _{xx}	0.020h _{xx}	0.015h _{xx}	NP	NP	NP
OMF	AISC 358 Prequalified Connections, But not meeting all requirements	AISC-358	Table 2.1.	Any Building Types	3.5	3	3	35	20	20	1	0.015h _{xx}	0.015h _{xx}	0.015h _{xx}	0.015h _{xx}	0.015h _{xx}	0.010h _{xx}
	Beam to Column Connection of Rolled or Built-Up I-Shape Sections Wide Flange Shapes ^k	AISC-341	Section E1	Any Building Types	3.5	3	3	35	20	20	1	0.015h _{xx}	0.015h _{xx}	0.015h _{xx}	0.015h _{xx}	0.015h _{xx}	0.010h _{xx}
	Moment Joint Field Connection Constructed of Bolted End Plates ^k	AISC-341	Section E1	Metal Buildings	3.5	3	3	65	20	20	1	0.020h _{xx}	0.020h _{xx}	0.015h _{xx}	NP	NP	NP
	Beam to Column Connection with Other Symmetrical Shapes ^l	AISC-341	Section E1	Light-Frame Construction or Miscellaneous Structures ^m	1.5	1.5	1.5	35	20	20	1	0.015h _{xx}	NP	NP	0.015h _{xx}	NP	NP

FOOTNOTE:

- Response modification coefficient R, for use throughout the standard. Note R reduces forces to a strength level, not an allowable stress level.
- Reflection amplification factor, C_d, for use in ASCE 7-16 Sections 12.8.6, 12.8.7, and 12.9.2
- NL = Not Limited, NP = Not Permitted, DL = roof or floor tributary dead load in accordance with ASCE 7-16 Section 12.2.5.6, 12.2.5.7, 12.2.5.8, WDL = exterior wall tributary dead load in accordance with ASCE 7-16 Section 12.2.5.6, 12.2.5.7, 12.2.5.8, HT = Heights are measured from the base of the structure as defined in ASCE 7-16 Section 11.2, For metric units use 30.5m for 100ft and use 48.8m for 160 ft, Story as defined in ASCE 7-16 section 11.2.
- The tabulated value of the overstrength factor, Ω_o , is permitted to be reduced by subtracting one-half for structures with flexible diaphragms, but shall not be taken as less than 2.0 for any structure except cantilever column system.
- See ASCE 7-16 Section 12.2.5.5 for limitations for steel SMFs in structures assigned to Seismic Design Category D through F.
- See ASCE 7-16 Section 12.2.5.6 and 12.2.5.7 for limitations for single-story steel OMFs and IMFs in structures assigned to Seismic Design Category D through F.
- See ASCE 7-16 Section 12.2.5.6 and 12.2.5.7 for limitations for steel OMFs and IMFs in structures assigned to Seismic Design Category D through E.
- See ASCE 7-16 Section 12.2.5.7 for limitations for steel IMFs in structure assigned to Seismic Design Category F.
- See ASCE 7-16 Section 12.12.1.1 for the allowable story drift for seismic force-resisting systems comprised solely of moment frames in Seismic Design Category D through F.
- See AISC 358-16 Table 2.1 for connections and limitations for prequalified steel SMFs with concrete structural slabs in direct contact with the steel.
- The connections in this table are intended for rolled or built-up I-shaped sections (i.e., wide flange shapes).
- Other double symmetrical (symmetrical to both bending axes) shapes may include, but not limited to, channels, built-up sections (non I-shaped), and hollow structural sections (HSS).
- Miscellaneous structures may include, but not limited to, walkways, canopies, penthouse, stairs towers, and other non-building structures not part of the lateral resisting system of a building.

As a covered entity under Title II of the Americans with Disabilities Act, the City of Los Angeles does not discriminate on the basis of disability and, upon request, will provide reasonable accommodation to ensure equal access to its programs, services and activities. For efficient handling of information internally and in the internet, conversion to this new format of code related and administrative information bulletins including MGD and RGA that were previously issued will allow flexibility and timely distribution of information to the public