

## HOW TO BRACE YOUR WATER HEATER

Water heaters must be strapped in at least two locations, one being in the upper one-third of the unit, and the other in the lower one-third. The lower strap must be a minimum of 4" above the water heater control unit. The required clearances from wall to heater as stated on the unit nameplate is critical. Lag screws not less than 1/4" in diameter must be used to anchor the restraints to the wall, and each lag screw must have at least 1-1/2" thread penetration into wall stud. A large flat washer must be installed between each lag screw and the strap for reinforcement.

**NOTE: Perforated iron strap (plumber's tape) will not be an acceptable method for strapping or bracing water heaters over 40 gallons.**

Example (wrap-around straps):

The State of California requires that all water heaters be strapped to resist motion during an earthquake. This may be accomplished by installing an over the counter "water heater restraint" kit approved by the Office of State Architect (O.S.A.).

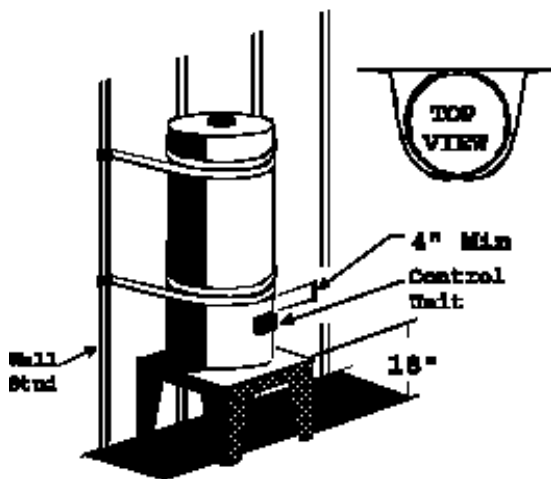

Drill pilot holes on centerline of stud (both sides of heater), insert screws through punched holes in strap. Use washers. Use minimum 22 Gauge X 3/4" wide metal strap.

