

SUPPLEMENTAL CORRECTION SHEET FOR THE BASELINE HILLSIDE ORDINANCE (BHO)
 (Ordinance No. 184,802 Effective 3/17/17)

Plan Review Date: _____
 Plan Check #: _____ Permit Application Number: _____
 Job Address: _____
 Plan Check Engineer: _____ Phone: _____ Email: _____

Your feedback is important, please visit our website to complete a Customer Survey at:
www.ladbs.org/LADBSWeb/customer-survey.jsf.

If you have any questions or need clarification on any plan check matters, please contact your plan check engineer and/or his or her supervisor.

This is a supplemental correction sheet. Please see the attached master correction sheet.

Italicized numbers refer to Code Sections of the 2020 Edition of the Los Angeles Residential Code or the current Zoning Code.

These corrections apply to new construction, additions, and major remodels to any Building or Structure on a lot in the R1, RS, RE, or RA Zones and in a designated Hillside Zoning Area (12.21C.10.):

PART I: SETBACK REQUIREMENTS

A. FRONT YARD SETBACK

1. Provide and dimension the required Front Yard setback. *12.21C.10(a)(1) & 12.21C.10(a)(2)*
 - a. The Front Yard setback shall not be less than the prevailing setback (40' max, 5' min). See Information Bulletin P/ZC 2002-015 for additional information.
 - b. Where a prevailing Front Yard setback cannot be established, provide (_____) ft. as required in the (_____) zone per Table 12.21C.10-1 or 5 ft. minimum for lots fronting a Substandard Hillside Limited Street
2. All portions of the required Front Yard not used for necessary driveways and walkways, including decorative walkways, shall be used for planting and shall not be paved. *12.21C.10(a)(5)*
3. On lots fronting onto a Substandard Hillside Limited Street, elevated stairways, porches, platforms and landing places shall not project or extend into the Front Yard. *12.21C.10(a)(11)(ii)*
4. Balconies projecting 30" maximum into the required Front Yard require a minimum of 10 ft. of vertical clearance beneath them. *12.21C.10(a)(11)(ii)*

B. SIDE/REAR YARD SETBACKS

1. Provide and dimension on plan: (____) Side Yard and (____) Rear Yard for the (____) zone per Table 12.21C.10-1. Any basement containing habitable rooms shall be considered a story. *12.21C.10(a)(8)*
2. For a lot located in the Coastal Zone, provide and dimension on plan: (____) Side Yard and (____) Rear Yard as required for the (____) zone. *12.21C.10(a)(9)*

3. In the R1 zone, where the Building or Structure has a side wall that exceeds a height of 14 ft. and has a length of 45 ft. or more, provide an offset/plane break that has a minimum depth of 5 ft., beyond the required Side Yard setback, for a minimum length of 10 ft. (*Table 12.21C.10-1*). See below for Example Figure 12.21 C.10(a).
4. In the R1 zone, any occupied rooftop deck shall be set back at least 3 ft. from the minimum required Side Yard setback. This does not apply to any rooftop deck located on the street side of a corner lot. *12.21C.10(a)(7)*

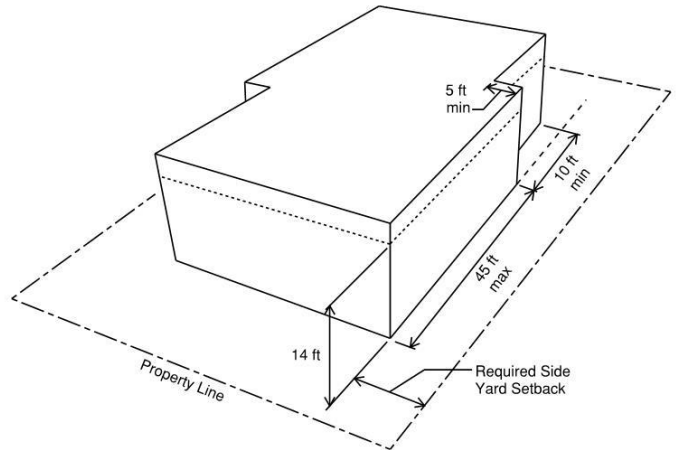

Figure 12.21 C.10(a): Plane break diagram

As a covered entity under Title II of the Americans with Disabilities Act, the City of Los Angeles does not discriminate on the basis of disability and, upon request, will provide reasonable accommodation to ensure equal access to its programs, services and activities

PART II: RESIDENTIAL FLOOR AREA (RFA), LOT COVERAGE, AND HEIGHT

A. MAXIMUM RESIDENTIAL FLOOR AREA (RFA)

1. Provide the original City Planning approved Slope Analysis Survey and Slope Band Analysis Maximum Residential Floor Area Verification Form. Attach both to the final permitted set of plans. A second copy is required for final permitting.

12.21C.10(b)(1)

- a. Note: No Slope Analysis is required if:
 - i. The project complies with the "Guaranteed Minimum Residential Floor Area per LAMC Section 12.21C.10(b)(2); or
 - ii. The addition complies with exception (2) of Section 12.21C.10 (I).

2. Provide a summary of the total site RFA. Clearly indicate the RFA per structure and any exemptions used. See RFA definition in LAMC 12.03

- a. Provide key plans of all buildings, clearly identifying all areas considered when calculating the existing and proposed RFA
- b. Provide complete cross sections specifying the heights of all rooms and attics. Rooms with a ceiling height greater than 14' shall be counted twice in the RFA. Portions of attics with a ceiling height of more than 7 ft. shall be included in the RFA. Provide floor plans and clearly identify areas which exceed the above thresholds (with hatching and dimensions)
- c. Detached accessory buildings which exceed 200 sq. ft. shall be included in RFA calculations. *The total combined area exempted of all detached accessory buildings on the lot shall not exceed 400 SF.*
- d. Porches, patios, and breezeways with a solid roof shall be included in the RFA calculations. Porches, patios, and breezeways with a lattice roof shall not be included in the RFA.
- e. Basement areas shall be included in the RFA calculations when the Elevation of the upper surface of the floor or roof above the Basement exceeds 3 ft. in height at any point above the finished or natural Grade, whichever is lower, for more than 60% of the perimeter length of the exterior Basement walls.

3. Maximum Residential Floor Area on any lot may be the percentage of the lot size per Table 12.21C.10-3 or 800 sq. ft., whichever is greater. 12.21C.10(b)(2)

4. Clearly identify which RFA bonus was used. This bonus only applies to the RA, RE, and RS zones. Only one bonus increase per property is allowed. 12.21C.10(b)(3)

- a. Proportional Stories Option – floor area of each story other than the Base Floor does not exceed 75% of the Base Floor area. Only allowed on lots where the building pad is less than 15% prior to any Grading.
- b. Front Façade Step Back Option – cumulative length (min. 25% bldg. width) of exterior walls, which are not a part of a garage, facing the Front lot line stepped back minimum 20% of building depth. Only allowed for structures which are no more than 35 ft. from the frontage along an improved street and on lots where the building pad is less than 15% prior to any Grading.

- c. Cumulative Side Yard Setbacks Option – combined Side Yard widths shall be min. 25% of lot width, but in no event shall a single Side Yard setback be less than 10% of the lot width or the minimum required Side Yard for the Zone, whichever is greater. The width of the required Side Yard setback shall be maintained for the entire length of a Side Yard.
- d. 18-Foot Envelope Height Option – Maximum 18 ft. envelope height for structures not in the "1SS" Single-Story Height District.
- e. Multiple Structures Option – Maximum 20% lot coverage for any one structure over 6 ft. above grade.
- f. Minimum Grading Option – for properties where a minimum of 60% of the lot is comprised of Slopes which are 30% or steeper, the total amount of any Grading (including exempted grading) in cubic yards does not exceed the numerical amount of the lesser of:
 - i. 10% of the lot area (_____), or
 - ii. 1,000 cubic yards.

5. The total proposed RFA of (_____) exceeds the maximum allowed by the following option:

12.21C.10(b)(3)

- a. Minimum Guaranteed RFA = (_____)
Total RFA with 20% Bonus = (_____)
- b. City Planning Approved RFA = (_____)
Total RFA with 20% Bonus = (_____)

B. VERIFICATION OF EXISTING RFA

1. Provide the following on plans:
 - a. Total existing RFA
 - b. Total maximum RFA approved by City Planning
 - c. Additional RFA
 - d. Total allowable RFA with bonus
 - e. Total proposed RFA with itemized exemptions
2. For additions with a cumulative RFA of less than 1,000 sq. ft. constructed after August 1, 2010, or remodels of Buildings built before August 1, 2010, the existing RFA shall be determined based on building records or the building square footage shown on the most recent Los Angeles County Tax Assessor's Records. RFA may also be calculated as defined in LAMC 12.03 when a complete set of fully dimensioned plans prepared by a licensed architect or engineer is submitted. 12.21C.10(c)
3. Provide a complete set of fully dimensioned plans with area calculations of all the structures on the lot prepared by a licensed architect or engineer to determine the RFA for additions 1,000 sq. ft. or larger and alterations where more than 50% of contiguous exterior walls or roof are not retained. 12.21C.10(c)

C. LOT COVERAGE

1. Lot coverage shall not exceed (40%) / (45%) for structures higher than 6 ft. above natural ground level for (standard / substandard) lot. 12.21C.10(e)

D. HEIGHT LIMITS

1. The building exceeds the (_____) ft. Maximum Envelope Height per Table 12.21C.10-4. Envelope height shall be the vertical distance from the Hillside Area Grade (as defined in LAMC 12.03) to a projected plane at the roof structure or parapet wall located directly above and parallel to Grade. 12.21C.10(d)(1)
2. Maximum one story allowed in a Single-Story Height District, "1SS." 12.21C.10(d)(4)
3. Maximum height, within 20 ft. of the front lot line, shall not exceed 24 ft. measured from the elevation at the centerline or midpoint of the street on which the lot fronts. 12.21C.10(d)(5)
4. Unenclosed/uncovered cantilevered balconies and "visually permeable railing" (42" or less) shall not exceed a maximum projection of 5 horizontal ft. beyond the Maximum Envelope Height.(12.21C.10(d)(1); 12.21C.10(d)(6))
5. Show that all Buildings and Structures in the R1 zone do not exceed the Encroachment Plane Height with an Encroachment Plane Origin Height of 20 ft. and Encroachment Plane angle of 45° measured from existing or finished grade whichever is lower. See Figure 12.03-1 to the right.
6. Projecting roof structures exceed the maximum height (_____) projection and setback (_____) per Table 12.21C.10-5.

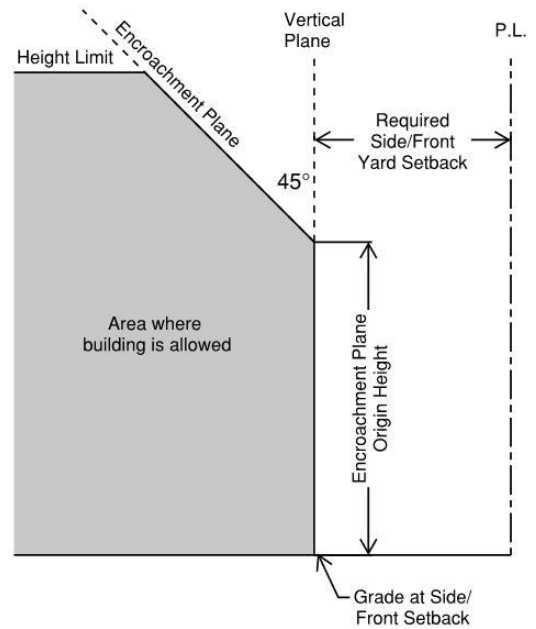

Figure 12.03-1: Encroachment Plane diagram

PART III: MISCELLANEOUS REQUIREMENTS

A. GRADING LIMITS

1. Grading quantities for the sum of Cut and Fill shall not exceed 1000 cubic yards plus 10% of the total lot size in cubic yards or (_____) cubic yards per Table 12.21C.10-6. 12.21C.10(f)(1)
2. The import and export combined quantity shall not exceed the "by-right" limit as listed in Table 12.21 C.10-6 for lots fronting on a Standard Hillside Limited Street. 12.21C.10(f)(2)(i)
3. The import and export combined quantity shall not exceed 75% of the "by-right" limit as listed in Table 12.21 C.10-6 for lots fronting on a Substandard Hillside Limited Street. 12.21C.10(f)(2)(i)
4. Note on plans: Earth import and export activities may take place only between the hours of 9:00 a.m. and 3:00 p.m., Monday through Friday.
5. Provide earthwork calculations clearly showing cut, fill, export and import quantities including bulking and swelling factors (in cubic yards) for exempted and non-exempted grading activities. 12.21C.10(f)(2) & (3)
6. Provide a geotechnical investigation Report (Soil and/or Geological report) for grading activity on any slope 100% or greater. 12.21C.10(f)(6)

B. OFF-STREET PARKING REQUIREMENTS

1. Provide (_____) additional off-street parking spaces in addition to the two required by the code. 12.21C.10(g)(2)
2. Tandem parking shall not be more than two cars in depth. 12.21C.10(g)(4)

C. FIRE SPRINKLER REQUIREMENTS

1. Provide an approved automatic fire sprinkler system on any lot fronting a Substandard Hillside Limited Street or located either more than 2 miles from a fire station housing a Los Angeles City Fire Department Truck Company or more than 1 ½ miles from a fire station housing a Los Angeles Fire Department Engine Company with scope as listed below: 12.21C.10(h)
 - a. New buildings or structures
 - b. Addition to an existing One-Family Dwelling or Accessory Building that increases Residential Floor Area by 50% or more of the existing floor area.
 - c. Major Remodel when the aggregate value within one-year period exceeds 50% of the replacement cost of the Dwelling or Accessory Building.

D. STREET ACCESS/SEWER

1. Show street dedication per Bureau of Engineering on plot plan. 12.21C.10(i)(1)
2. Obtain City Planning approval per 12.24X28 for new construction or addition to dwelling if lot:
 - a. Fronts on a Substandard Hillside Limited Street with a roadway width less than 20 ft. 12.21C.10(i)(2)
 - b. Does not have a vehicular access route equal to or more than 20 ft. from the driveway providing access to main residence to the boundary of the Hillside Area. 12.21C.10(i)(3)

