

ALLOWABLE PROJECTION FOR DECKS AND BUILT-UP PLATFORMS IN REQUIRED YARDS

The following sketches and notes specify the permissible height and maximum horizontal projection of accessory residential decks, porches or landings when located within the yards required for the main building on the lot.

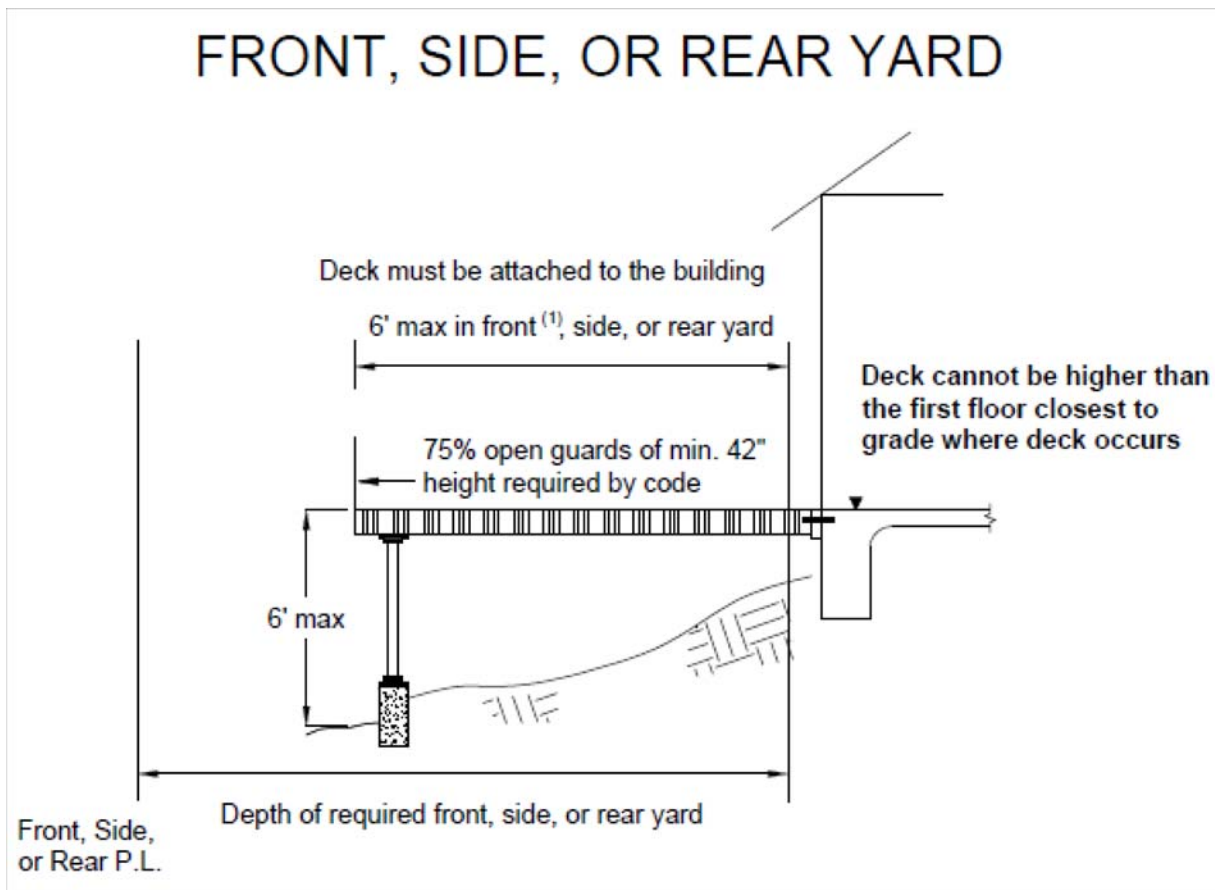

- (1) This projection is not allowed in the front yard if the lot is subject to the Hillside Ordinance or Baseline Hillside Ordinance . (LAMC Sec. 12.21A17(e), LAMC Sec. 12.21C10)

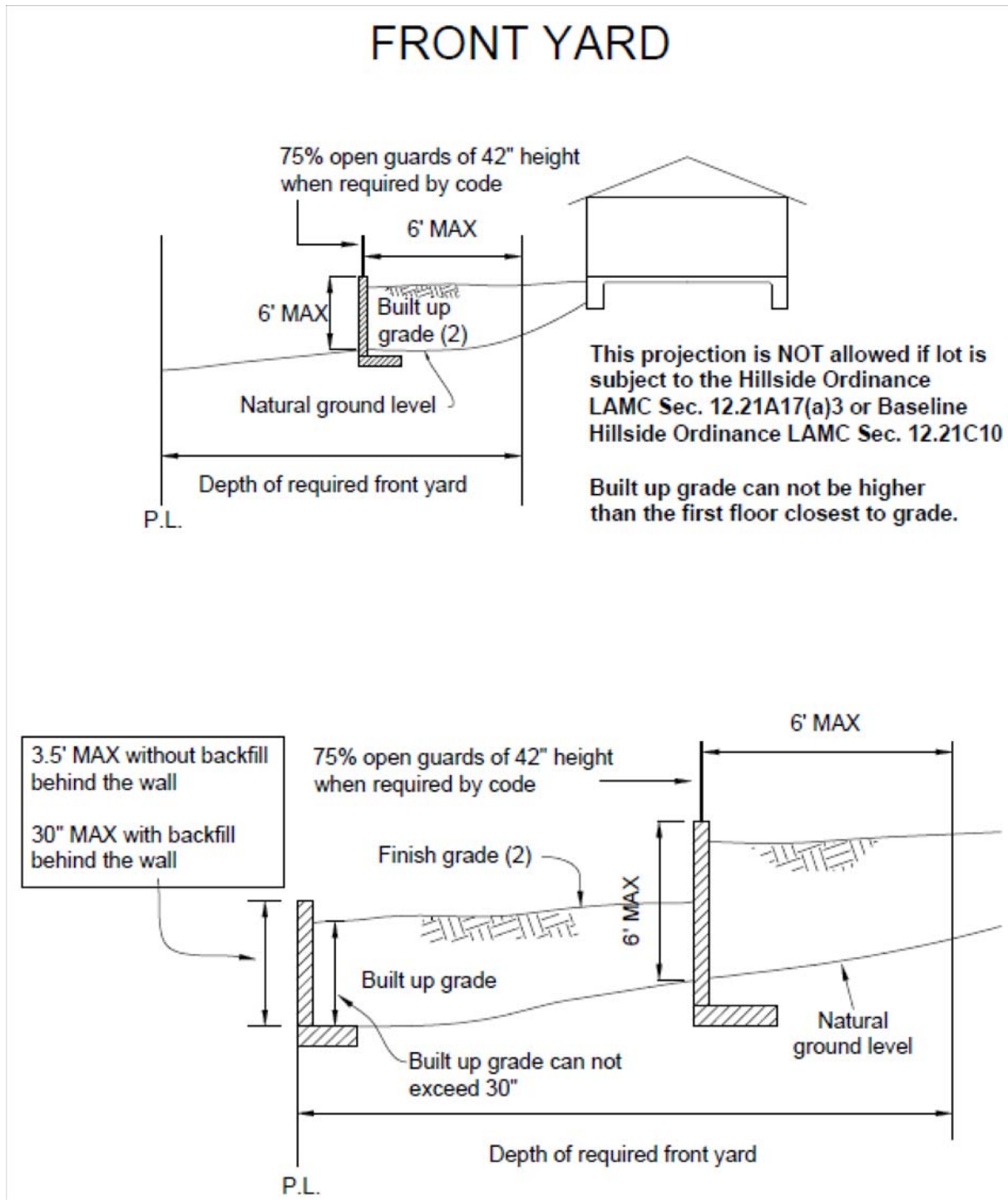

- (2) A swimming pool built above the grade shall be considered a deck for the purpose of a permitted projection of a swimming pool into the required yards. The location of a swimming pool shall meet the requirements of LABC Section 3109.

As a covered entity under Title II of the Americans with Disabilities Act, the City of Los Angeles does not discriminate on the basis of disability and, upon request, will provide reasonable accommodation to ensure equal access to its programs, services and activities. For efficient handling of information internally and in the internet, conversion to this new format of code related and administrative information bulletins including MGD and RGA that were previously issued will allow flexibility and timely distribution of information to the public.

SIDE or REAR YARD

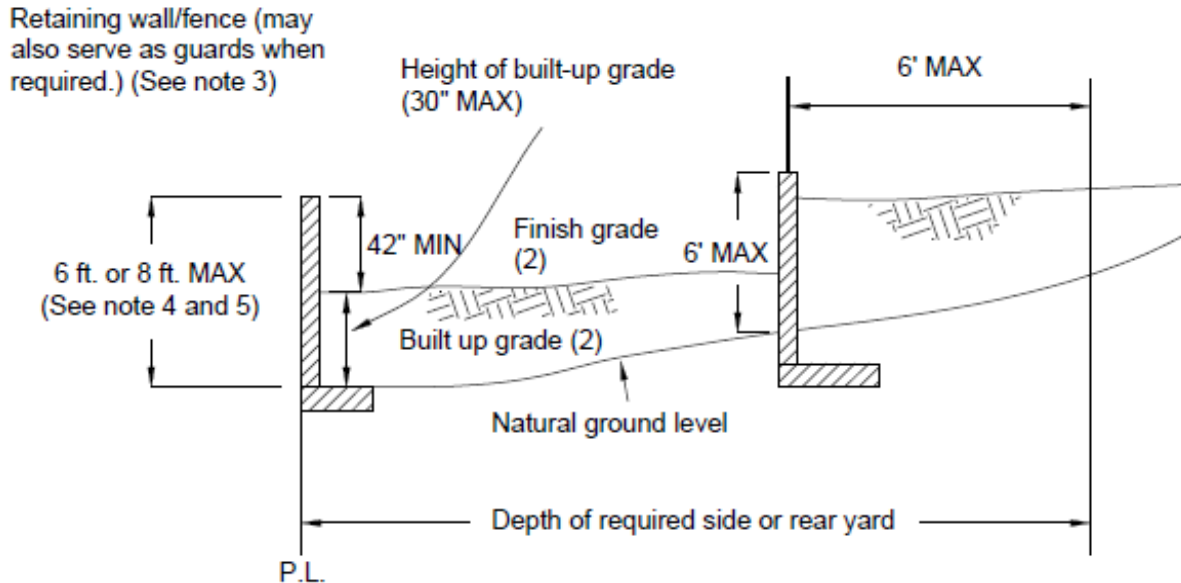
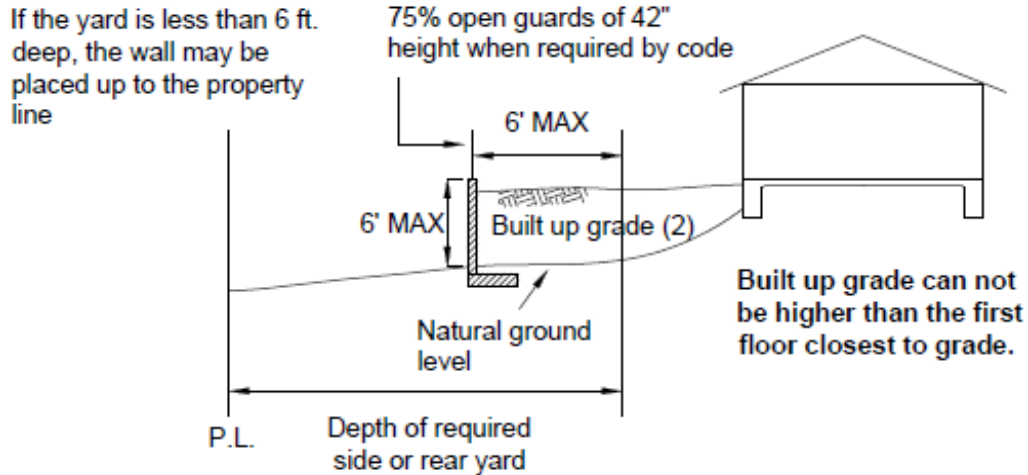

- (2) A swimming pool built above the grade shall be considered a deck for the purpose of a permitted projection of a swimming pool into the required yards. The location of a swimming pool shall meet the requirements of LABC Section 3109.
- (3) Height of the wall/fence cannot exceed the allowable height of a fence (Typically 8' in side and rear but cannot exceed 6' in side and rear in hillside areas or in lots less than 40' wide). See LAMC 12.22C20(f)
- (4) Raised walking surfaces higher than 30" require protection guards. LABC 1013
- (5) If guards are required, such guards must be 42" high for all uses. The height of the guards must be included in the measurement of the overall height of the wall/fence regardless of whether the guards are of open (wrought iron) or solid construction.

Notes:

- A. LAMC Section 12.22C20(e) Decks/Platforms are permitted in the required yards pursuant to “Open, unenclosed porches, platforms or landing places (including access stairways thereto), not covered by a roof or canopy, which do not extend above the level of the first floor of the building, may extend or project into the required front yard, side yard, rear yard, passageway or other open spaces, not more than six feet, provided that in no event shall any such porch, platform or landing place be more than six feet above the natural ground level adjacent thereto. (*Amended by Ord. No. 138,685, Eff. 7/10/69.*)” (Exception: This provision does not apply to front yards of lots subject to the Hillside Ordinance or Baseline Hillside Ordinance)
The term “floor” shall be interpreted to be the first floor higher than grade at the location where the deck occurs and NOT necessarily the first story of the building.
- B. In determining the height of a building, *detached* decks may be considered as separate structures only if they are at least 10 ft. away from such building. ***The detached deck shall not project into any required yards.***
- C. The yards referred to herein are those required for the main building on the lot.
- D. Decks or any similar structure must comply with LAMC Section 12.22C20(l) which states in part “... no architectural feature, ... or other projection permitted in a yard... shall be located and maintained so as to preclude complete access about and on each side of and in close proximity to main buildings and accessory living quarters at all times.”
- E. Retaining walls supporting built-up platforms in the designated hillside grading area shall be included in the maximum number of retaining walls permitted pursuant to LAMC 12.21C8(a).