

## HEIGHTS OF FENCES IN RESIDENTIAL ZONES

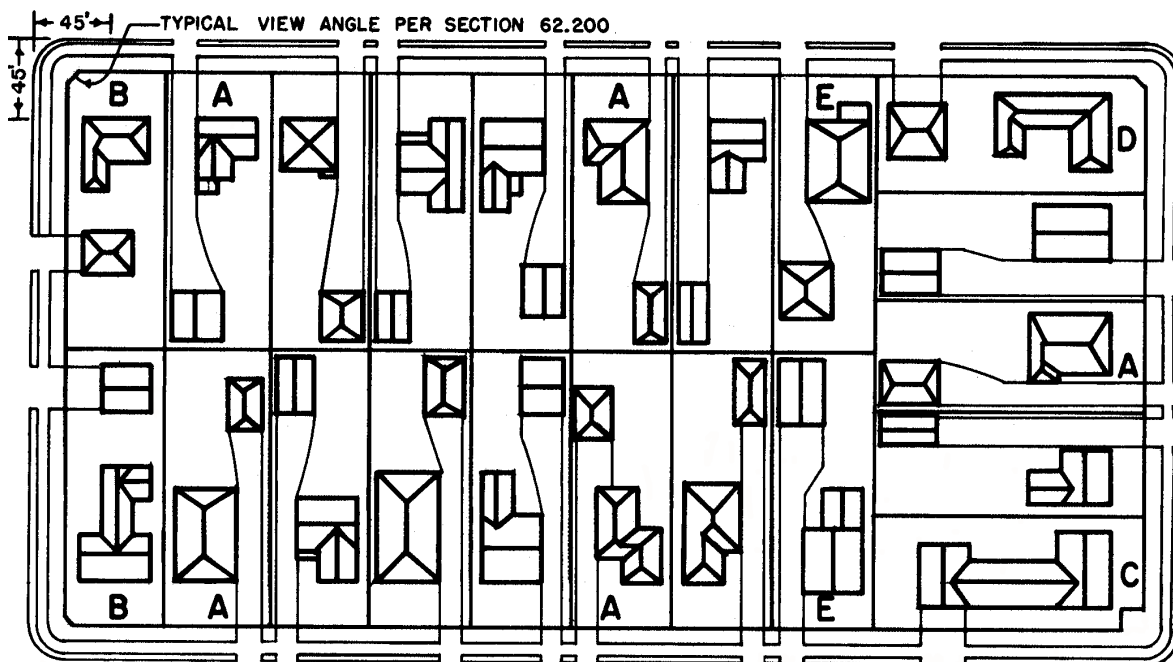

FENCE HEIGHTS IN REQUIRED YARDS

FRONT YARD FENCES

ZONE: A, RA - 6 FT. \*

R, RW -3.5 FT.\*

SIDE AND REAR YARD FENCES

ZONE: A, RA, R - 8 FT. IF LOT WIDTH IS 40 FT. OR GREATER AND NOT IN HILLSIDE AREA. 6 FT. IF LOT IS LESS THAN 40 FT. OR IN THE HILLSIDE AREA

\* 8 FT. FENCE PERMITTED WITH DEPARTMENT OF CITY PLANNING APPROVAL. PERMIT REQUIRED FOR MASONRY OR CONCRETE FENCES OVER 3 ½ FT. HIGH.

CAUTION! DO NOT ASSUME INSIDE EDGE OF THE SIDEWALK AS THE PROPERTY LINE.

FOR "PREVAILING SETBACK" SEE THE CITY OF LOS ANGELES COMPREHENSIVE ZONING CODE.

**METHOD OF DETERMINING MAXIMUM FENCE HEIGHT ON SLOPING GROUND**

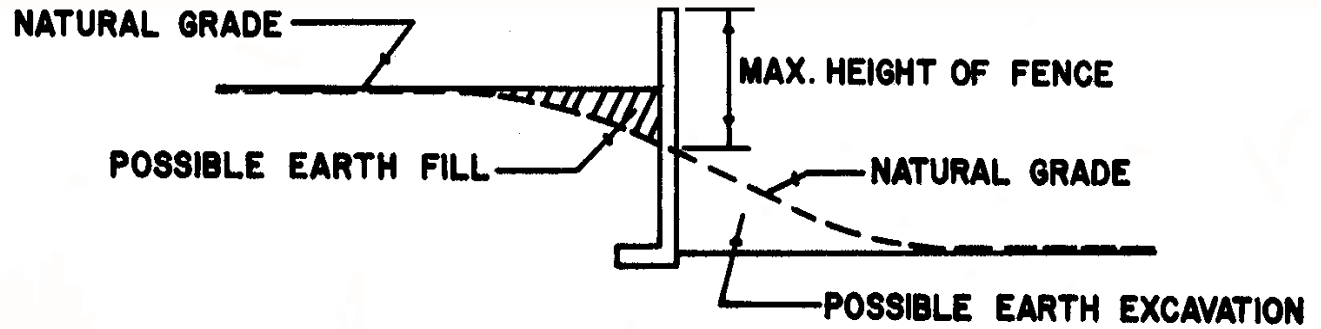

For additional information regarding this bulletin, please contact the plan check supervisor at:

Metro Office  
201 N Figueroa St.  
8 th Floor  
(888) 524-2845

Van Nuys  
6262 Van Nuys Blvd.  
Room 251  
(888) 524-2845

West Los Angeles  
1828 Sawtelle Blvd.  
2 nd Floor  
(888) 524-2845

For telephone inquiries originating from outside of Los Angeles County, call (213) 482-0000.

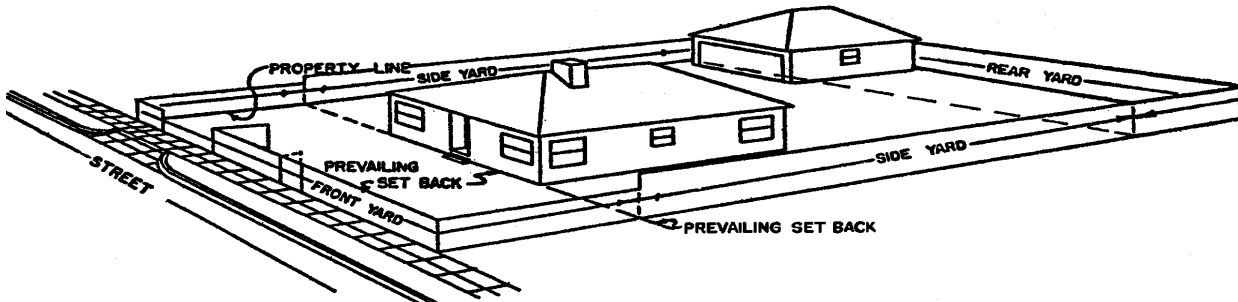

TYPICAL INSIDE LOT-A (SIMILIAR FOR KEY LOT-E)

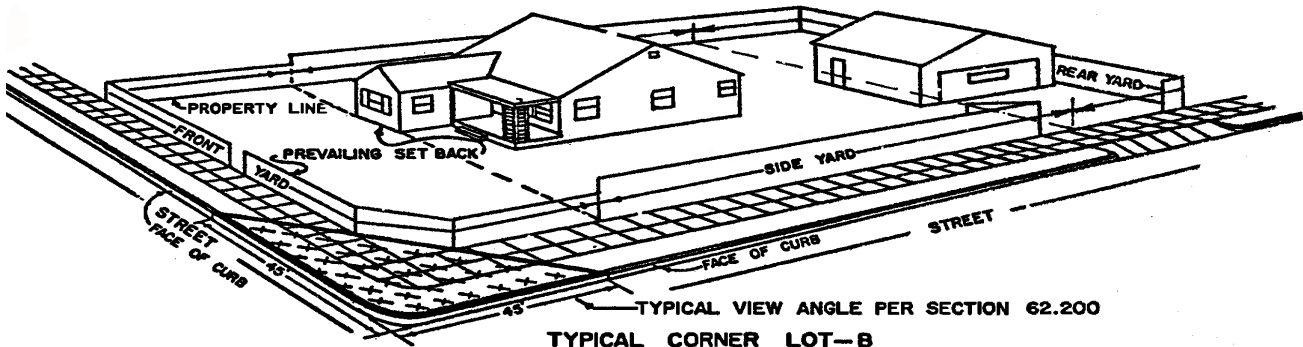

TYPICAL CORNER LOT-B

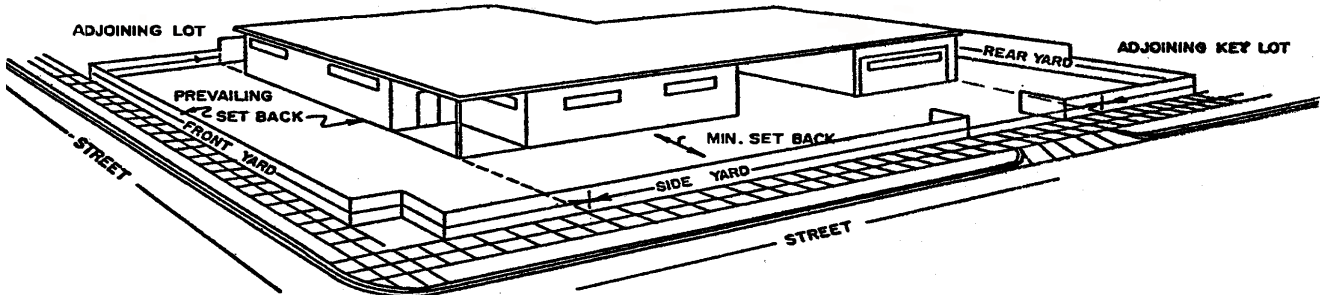

TYPICAL REVERSE CORNER LOT-C

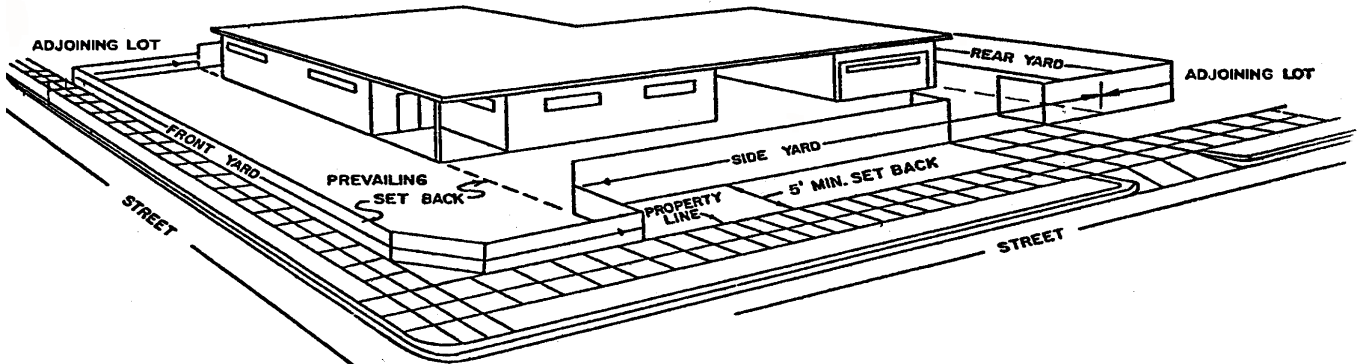

TYPICAL REVERSE CORNER LOT-D